

REQUEST TO PARTICIPATE QUESTIONNAIRE

(TO BE AMENDED FOR USE AS APPROPRIATE DEPENDING ON TYPE OF CONTRACT. QUESTIONS CAN BE DELETED AND OTHERS INSERTED AS APPROPRIATE. QUESTIONS RELATING TO EQUALITIES, SUSTAINABILITY AND FINANCE SHOULD ALWAYS BE INCLUDED.)

WEST MERCIA SUPPLIES

CONTRACT REFERENCE NUMBER AND DESCRIPTION

1 Copy to be returned to:

The Managing Director
Purchasing Office
West Mercia Supplies
Holsworth Park
Oxon Business Park
Bicton Heath
SHREWSBURY
SY3 5HJ

by 4 pm (INSERT RETURN DATE)

Insert Name of Company

This document consists of (INSERT NUMBER OF PAGES) and must be completed in its entirety.

Please read page 2 carefully before completing this document.

WEST MERCIA SUPPLIES

REQUEST TO PARTICIPATE QUESTIONNAIRE

INSTRUCTIONS ON COMPLETING THE QUESTIONNAIRE

1. This document must be completed in its entirety with responses being given to all questions. One copy must be returned.
2. Where figures are requested these must be inserted in the tables as indicated, it will **not** be sufficient to refer to supporting documents/accounts.
3. **All questions require specific responses from you relating to the Company Named in Section A Question 1.** It is not appropriate for the Contracting Authority to attempt to construct an answer by the selection of what it deems as appropriate elements that may be given in the body of general supporting information. It is a requirement that each question is addressed by you to ensure that the correct information is presented to enable a judgement to be made on your ability to be considered for inclusion in the tendering process.
4. Where accounts, and other details, are requested a copy **must** accompany your Request to Participate Questionnaire.

Particular Points to Note

- a) Question 1 page 4 - Where exact figures are not known, please give your best estimate and indicate that you have done so.
- b) Question 2 page 4 - You are required to supply **audited** accounts for the past 3 years for your company. Additionally, if the latest audited accounts are more than six months old, **copies of current un-audited accounts or latest management accounts must be sent.**
- c) Question 1 page 16 - You must include all the details requested including the value of the contract.

We would finally point out that unless you provide all the information requested in this document you risk not being further considered for inclusion in the tendering process.

WEST MERCIA SUPPLIES

SECTION A – SERVICE PROVIDER / SUPPLIERS / CONTRACTORS DETAILS

1. Name of Company
2. Type of Company
(private, limited liability etc)
3. Details of association to any holding company, subsidiary or group of which you are a member.

.....

.....

.....

4. Please state for how many years your organisation has been undertaking contracts for **(TO BE INSERTED)**
-

5. Total number of staff employed in the last 3 years.

Year	2003	2004	2005
Number of staff			

6. Number of employees engaged in the following categories during the past 12 months.

Partners/Directors
Management
Purchasing
Sales
Manufacturing / Production
Quality Control
Others (specify)
Total

WEST MERCIA SUPPLIES

SECTION B - FINANCIAL DETAILS

1. Brief summary of your annual turnover and profit in the last 3 years.
(Please insert figures - do not refer to attached accounts).

<u>Company</u>		
<u>Year</u>	<u>Turnover</u>	<u>Profit (Loss)</u>
20	£	£
20	£	£
20	£	£

2. Please supply audited accounts for the past three financial years for your Company.
 If the latest audited accounts are more than six months old copies of current un-audited accounts or latest management accounts must be sent.

<u>Year</u>	<u>Accounts Enclosed</u>
20	YES/NO
20	YES/NO
20	YES/NO

3. Please show below your company's approximate turnover in relation to the supply of **(TO BE INSERTED)** in the last three financial years.
(Please insert figures - do not refer to attached accounts).

<u>Year</u>	<u>Turnover in relation to the supply of (TO BE INSERTED)</u>
20	£
20	£
20	£

WEST MERCIA SUPPLIES

**SECTION C - PAPER SPECIFICATION, SOURCES OF PAPER AND ENVIRONMENTAL ISSUES
(THIS SECTION WILL CHANGE, OR MAY NOT BE INCLUDED AT ALL, DEPENDING ON THE
PRODUCT OR SERVICE BEING TENDERED. THE FOLLOWING DETAIL IS AN EXAMPLE OF THE
TYPE OF INFORMATION THIS SECTION MAY CONTAIN.)**

1. Paper Specification

Our paper specification is as follows:

	Description	Unit	Value	Standard
1.	Basis weight and its allowable variation, not exceeding	g/m ²	75±5%	ISO 536
2.	Whiteness, average both side, not below	Points	136±3	CIE standard
3.	Sizing, Coob60, average both side	g/m ²	Max 22	ISO 535
4.	Moisture	%	5 - 8	ISO 287
5.	Smoothness, Bekka 10 cm ³ , average both side, not below	s	35	ISO 5627
6.	Opacity, not below	%	86.0	ISO 2471

Sizing

The paper must be coated with sufficient sizing to resist ink absorption and to ensure that there is no show through of ink onto the reverse side of the sheet.

Can you supply paper that meets our specification? YES / NO

2. Please provide the following information in respect of pulp and paper mills used by your company who can supply paper that meets our specification. This information is requested for both virgin and recycled paper.

Virgin Paper

- (i) Name of mill
- (ii) Country in which mill is located
- (iii) Ultimate parent company owning the mill
- (iv) Is the mill ISO 14001 approved?
- (v) If the answer to the previous question is NO, is the mill working towards achieving this accreditation and when does it expect to meet the environmental standards required by ISO 14001?
- (vi) What other environmental standards does the mill meet?
- (vii) From which country does the pulp/fibre used by the mill originate?

Virgin Paper (continued)

- (viii) What action does the mill take to ensure that all pulp/fibre used by them originates from managed and sustainable sources.
.....
.....
.....
- (ix) Has the paper been accompanied by an FSC Chain of Custody Certificate? YES / NO
- (x) Has the paper offered been certified by the FSC? YES / NO

Recycled Paper

- (i) Name of mill
- (ii) Country in which mill is located
- (iii) Ultimate parent company owning the mill
- (iv) Is the mill ISO 14001 approved?
- (v) If the answer to the previous question is NO, is the mill working towards achieving this accreditation and when does it expect to meet the environmental standards required by ISO 14001?
- (vi) What other environmental standards does the mill meet?
- (vii) From which country does the pulp/fibre used by the mill originate?
- (viii) What action does the mill take to ensure that all pulp/fibre used by them originates from managed and sustainable sources.
.....
.....
.....
- (ix) Has the paper been accompanied by an FSC Chain of Custody Certificate? YES / NO
- (x) Has the paper offered been certified by the FSC? YES / NO

WEST MERCIA SUPPLIES

SECTION E - MANUFACTURING AND STORAGE CAPABILITY (PARTS OF THIS SECTION MAY NOT BE INCLUDED)

- 1. When awarding contracts West Mercia Supplies will only consider manufacturers of **(TO BE INSERTED)**. Suppliers who are not manufacturers will not be considered. **(THIS REQUIREMENT MAY VARY DEPENDING ON THE PRODUCT(S) BEING TENDERED)**.

- 2. It will be a condition of contract that any supplier awarded any part of this contract must manufacture stocks during the period required by West Mercia Supplies and must then hold stocks for call off.

- 3. Do you have the capability of manufacturing our total requirement for all products during the period December to March each year and for all product manufactured to be stored for up to 12 months and called off by West Mercia Supplies as appropriate during the 12 month period commencing 1 April each year?

YES / NO

- 4. Please state below the area, in square metres, that you will have available to store West Mercia Supplies **(TO BE INSERTED)**

.....
.....

- 5. How many pallets, measuring 1 x 1.2 x 1.275 m can you hold in this storage area?

.....
.....

- 6. Please confirm that this storage space is fully weather proof and suitable for storing **(TO BE INSERTED)** all year round.

.....
.....

- 7. How close is your storage space to your manufacturing facility?

.....
.....
.....

- 8. Your attention is drawn to the attached Pallet Specifications Document which must be strictly adhered to by any company supplying West Mercia Supplies with **(TO BE INSERTED)**.



PALLET SPECIFICATION DOCUMENT

A. Pallet Construction

1. All pallets used to supply goods to WMS must comply with this specification sheet.
2. All pallets are to be constructed of sound wood (ie no splits or excessive knots), must be 4 way entry and be 100 cm x 120 cm (40" x 48") in size.
3. The top deck boards must be 2 cm thick and placed along the 100 cm width. Any gaps between the top deck boards must not exceed 4 cm.
4. The top deck boards must be supported on stringer boards each 2 cm thick. All stringer boards must run along the 120 cm length.
5. The stringer boards must be supported on blocks or cubes which must be at least 8 cm on each dimension. All blocks or cubes must be free from damage with no projecting nails.
6. The blocks must be secured to the perimeter base boards. All base boards must be 2 cm thick with chamfered edges to aid pallet handling using mechanical means.
7. As a minimum, there must be three perimeter base boards running along the 120 cm length. Each base board must be at least 8 cm wide and fastened to each block with two or more nails each 6 cm long to meet BS ISO 12777-1. All nails used must be at least 4 mm diameter and have adequate edge distance.
8. Where perimeter base boards are used on all four sides it is important that those running along the 120 cm length overlap at least 50% of the block to which they are secured.
9. Diagrams showing methods of construction and dimensions are as follows:

Pallet Top

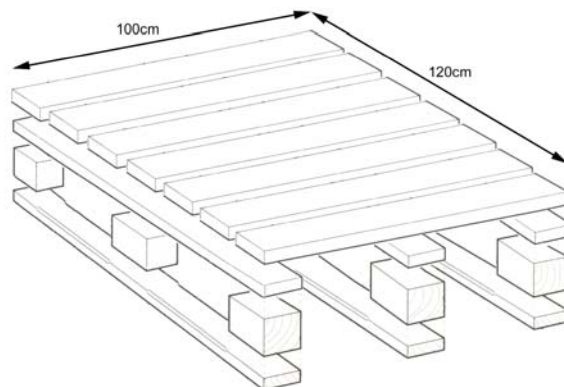
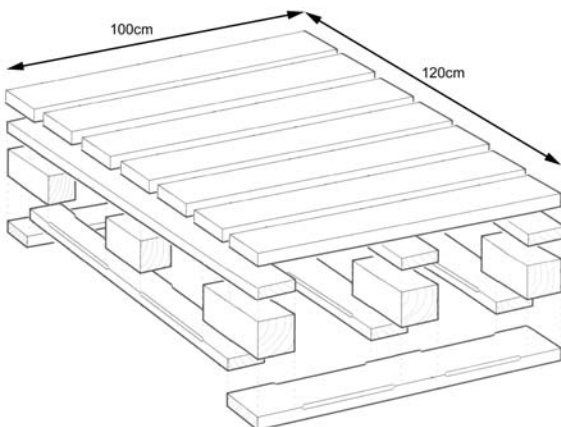

Pallet Bottom

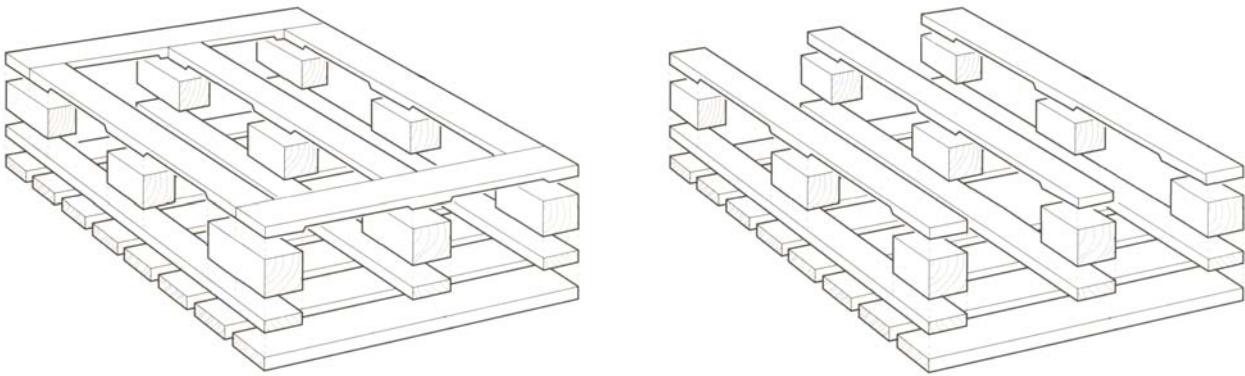

10. All pallets must be supplied without any protruding nails, and there must be no loose joints which allow movement in the pallet (diamonding).

B. Pallet Loading

1. All goods supplied on pallets must be securely packed ensuring that the pallet used is capable of safely taking the weight of the goods being delivered.
2. Packages or product must be stacked in suitable layers with alternative layers set at right angles to bind the product into the stack. All pallets must be stacked squarely to ensure no leaning of product on the pallet.
3. No goods must overlap or overhang any edge of the pallet.
4. The total weight of the goods and the pallet must not exceed 1,000 kg.
5. The total height of the goods and the pallet must not exceed 127.5 cm (51").
6. Where possible WMS will order in sufficient quantity to ensure that individual catalogue numbers are stacked on separate pallets. Where this is not possible complete layers must be made up of single catalogue numbers. A further pallet should be stacked on top of completed layers of the first catalogue number and a second catalogue number stacked on this second pallet. This can continue until the height of the total stack of all the pallets is 127.5 cm and/or 1000 kg in weight.
7. All palletised deliveries must be securely shrink wrapped or banded to ensure no movement of goods during transit.
8. Each pallet of goods must be clearly marked with an A4 sheet secured to the side of the stack of goods giving the WMS catalogue number, product description and quantity supplied on the pallet.
9. All pallets are to be supplied free of charge, and the contractor will be responsible for arranging for the collection and return of empty pallets where required. Where pallets are to be collected, at least 4 weeks notice must be given to WMS.
10. If WMS warehouse staff are to unload a palletised delivery from a container, then there must be at least a 15 cm gap between each pallet on the container. Where this gap is not present, WMS will be unable to unload containers and the delivery will be rejected.

C. Deliveries

1. It will be a condition of contract that all palletised deliveries must comply with the details as set out in this Pallet Specification Document.
2. Where goods are supplied on pallets which do not comply with this Specification Document WMS will have, at its sole discretion, the right to reject either specific pallets or the whole of the delivery or to re-stack the delivery onto pallets meeting this Specification Document.
3. In the case of rejection, the supplier will immediately remove the rejected pallets or the delivery, as appropriate, and re-arrange for its re-palletisation. Any return delivery must be pre-booked with our Stock Controller in the normal way. The supplier will be responsible for all costs incurred by WMS as a result of this rejection, including any additional costs resulting from the need to purchase emergency stocks to maintain continuity of supply to our customers.
4. Where WMS opts to re-stack the rejected pallets, the supplier agrees to pay to WMS its reasonable costs incurred as a result. The minimum charge to be paid by the supplier will be £20 per pallet.
5. In all cases of rejection, WMS will issue a Pallet Rejection Notice, clearly indicating the reasons for rejection, and highlighting the areas of the pallet/delivery which are not in accordance with this Specification Document.
6. By accepting the order from WMS, the supplier confirms acceptance of this Pallet Specification Document and its inclusion into any contract between the supplier and WMS.
7. Suppliers will be aware of their obligations under the Health and Safety at Work Act, and the need to ensure that the quality of pallets used to move and store their goods and the methods of delivery used do not fall outside the requirements of that Act.

9. As a manufacturer of **(TO BE INSERTED)** please list below all of your manufacturing sites, together with the information requested on machines available at each manufacturing site for making **(TO BE INSERTED)**.

Primary Manufacturing Site

Address of site _____

Please detail which products are made at this site _____

Please list the following information for each **(TO BE INSERTED)** making machine

<u>Machine No</u>	<u>Manufacturer of machine</u>	<u>Model No</u>	<u>Age of machine</u>	<u>Output capability of the machine per hour</u>
1.				
2.				
3.				
4.				
5.				
6.				

Secondary Manufacturing Site

Address of site _____

Please detail which products are made at this site _____

Please list the following information for each **(TO BE INSERTED)** making machine

<u>Machine No</u>	<u>Manufacturer of machine</u>	<u>Model No</u>	<u>Age of machine</u>	<u>Output capability of the machine per hour</u>
1.				
2.				
3.				
4.				
5.				
6.				

WEST MERCIA SUPPLIES

SECTION F - PRODUCT RANGE (*THIS SECTION WILL CHANGE DEPENDING ON THE PRODUCT OR SERVICE BEING TENDERED*)

You are required to confirm the range of **(TO BE INSERTED)** you can manufacture by placing a tick in each box, as appropriate.

WEST MERCIA SUPPLIES

SECTION G - TECHNICAL EXPERIENCE AND QUALITY CONTROL PROCEDURES

- 1. If a company, please supply proof of enrolment on a professional or trade register or register of companies in the country in which the company is established

Proof enclosed

- 2. Has the Company Named in A or the Group/Ultimate Holding Company:
 - a) ever suffered a deduction for liquidated and ascertained damages in respect of any contract within the last 3 years?
.....
.....
 - b) ever had a contract terminated under the terms of the contract?
.....
.....
 - c) ever been unsuccessful in securing a contract renewal because of failure to perform under the terms of the contract?
.....
.....

If the answer to any of the questions 2a, 2b, or 2c above is 'yes' please enclose details.

- 3. Please state any formal quality assurance systems which your company operates and for which it holds registration together with the registration numbers. You should also state to which areas of your company's operations the quality assurance systems apply e.g. manufacturing / production, service, administration etc.
.....
.....
.....
.....
.....
.....
.....
.....

WEST MERCIA SUPPLIES

SECTION H - OTHER DETAILS

1. Please list below up to a maximum of 10 similar contracts (i.e. those involving the supply of **(TO BE INSERTED)** for other Local Authorities or similar bodies) undertaken by your company in the past three years or currently being handled. **(All details requested must be given).**

<u>Awarding Authority</u>	<u>Contact & Tel No</u>	<u>Value of Contract £</u>	<u>Nature of Contract</u>	<u>Date of Award</u>	<u>Date Completed</u>
1.					
2.					
3.					
4.					
5.					
6.					
7.					
8.					
9.					
10.					

Please note - the Contracting Authority reserves the right to seek references from all or any of the bodies identified above.

2. Is it your policy as an employer to comply with your statutory obligations under the Race Relations Act 1976 (as amended) and Equal Opportunities Legislation and, accordingly, your practice not to treat one group of people less favourably than others because of their colour, race, nationality or ethnic origin or gender in relation to decisions to recruit, train or promote employees?

YES	NO
------------	-----------

3. Details (if any) of all prosecutions, prohibitions or improvement notices served on your organisation or any person mentioned in the Questionnaire by the Health and Safety Executive (Factory Inspector), Environmental Health Officer, Trading Standards Officer, The Fire Service, any Court or Industrial Tribunal or the equivalent to any of these bodies in other EU Member States.

.....

.....

.....

.....

.....

4. It will be a condition of contract that any Ultimate Group/Holding Company must guarantee the performance of this contract, if it is awarded to a subsidiary. If the company named in A is a subsidiary company, please enclose a letter from the Ultimate Group or Holding Company, signed by a duly authorised signatory of the Ultimate Group/Holding Company, guaranteeing performance of the contract in the event of it being awarded to your company.

Letter enclosed (tick)

6. Declaration

I understand that the responses I have given in this Request to Participate Questionnaire, together with any supporting documentation, are to be used as a basis for selection of companies to whom tender documents will be issued.

I note that the Contracting Authority reserves the right to undertake supplementary stages of selection prior to the issue of a formal invitation to tender.

I confirm that if I am awarded a contract all of the information I have provided in this Request to Participate Questionnaire together with any supporting documentation will be deemed to be part of the contract.

Signed Name
(please print)

Designation Date

Company

Address

..... Post Code

Tel No Fax No

**THE CLOSING DATE FOR RECEIPT OF THIS INFORMATION IS
4 PM ON (TO BE INSERTED)**